



Detectors

Infrared flammable gas detector you can trust

Nimbus

Nimbus

Nimbus is compact and lightweight but rugged. Maintenance is simple, and because it is compatible with handheld and laptop computers, units can be checked by a single engineer.

It can be integrated into existing systems with ease. Nimbus protects staff and property without making your life complicated.

Rugged & reliable

Nimbus has been designed to be **lightweight but tough**.

Even in the dirtiest conditions Nimbus still functions. The optics operate at up to 90% obscuration. While still detecting gas, at 75% obscuration a dirty optics warning flashes **so you know when to clean Nimbus.**

Dust and water ingress are not a problem either as **Nimbus is rated IP66 and IP67.** Allied to this Nimbus has full approvals from both **EUROPE and North America.**

Nimbus has a **MTBF of 10 years.** This figure has been independently assessed using the MIL Handbook 217F/2/12/91

In short you can rely on Nimbus to protect you.

One man calibration

Nimbus is compatible with Windows software, which means that a Windows compatible **portable PC can be used to check gas levels, find faults and change configurations in the field.** Only one person is required to do this.

Nimbus is fitted with an optical Communications Interface Module, to allow **connection of a PC without opening the detector.**

For detectors installed in a hazardous area, the configuration and status can be checked remotely using the Modbus serial link.

Simple maintenance

Nimbus has a local external status light which shows, at a glance, if the unit is in normal function or fault. When a hazard is detected it indicates both rising gas and alarm levels.

The status light clearly indicates 22 further conditions for **instant diagnosis.**

Nimbus is simple to use even in inaccessible areas. A duct mounting plate is available, which incorporates a **remote gassing port** to allow calibration checking without requiring entry into the duct.

Flexible installation

Nimbus can be integrated into existing situations with ease. It has a RS485 output and dual redundant 4-20mA outputs, compatible with metric and imperial armoured cable and conduit.

The **Modbus serial link** allows addressable detectors to be looped **providing a remote control and interrogation facility.**

For facilities where Nimbus is replacing a pellistor based detector the **pellistor mimic means that existing cabling can be retained to reduce upgrade costs.**

Nimbus, the total system solution

It can interface with any standard control system, or combination of systems, new or old.

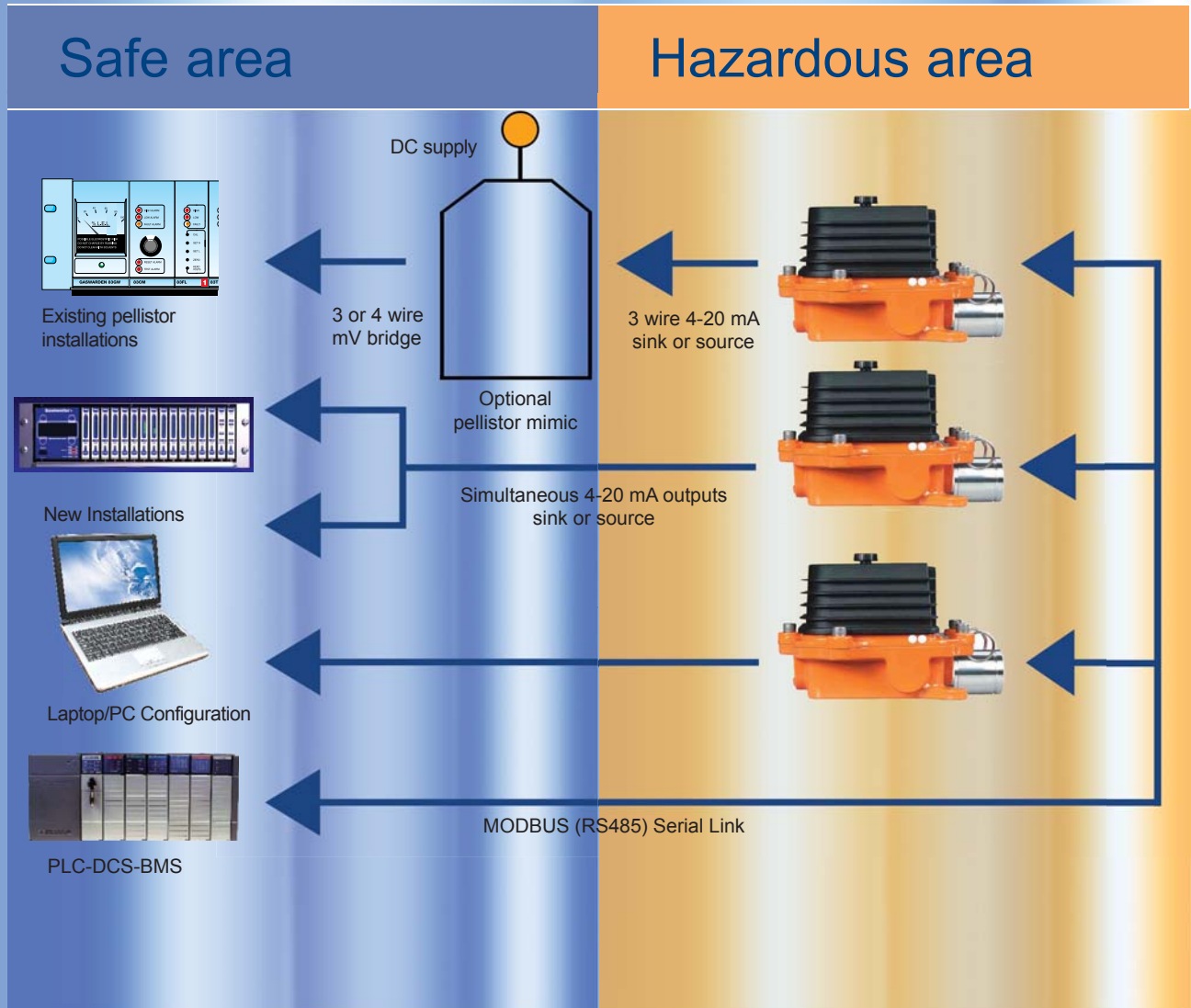

Mounting Options

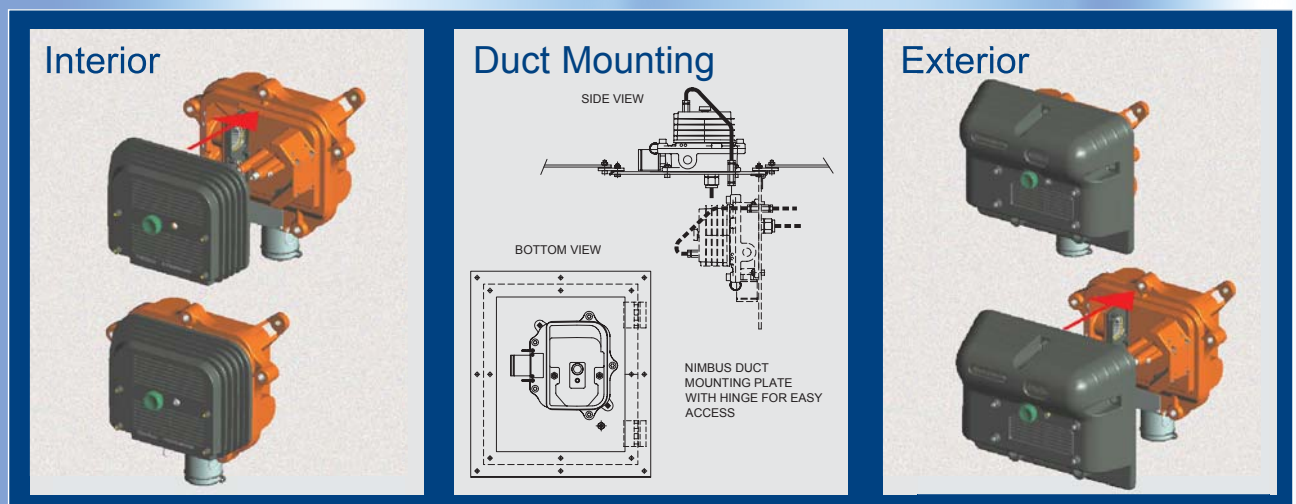

Nimbus

Infrared flammable gas detector



Model	Nimbus
Function the list of available	The detection of hydrocarbon gases C 1 to C 6 + ethanol, ethylene and LPG in the LEL range by means of infrared absorption. Contact Crowcon for a full list of available gases and ranges.
Dimensions	125 x 170 x 210 mm (5 x 6.8 x 8.3 ins)
Weight	2.5 kg, (5.5 lbs)
Construction	LM25 marine grade alloy, polyester powder coated
Optical system	Dual wavelength, dual detector
Optical performance	Correct operation with up to 90% obscuration Dirty optics warning above 75% (configurable) Heated optics to avoid condensation.
Power consumption	Operating voltage: 10 to 32 V dc (nominal 24 V)
– LK2 fitted (Anti Condensation Heater)	Operating current: 300 mA max (7.2 W @ 24 V, 3 W @ 10 V)
– LK2 not fitted	Operating current: 180 mA max (4.3 W @ 24 V, 1.8 W @ 10 V)
Typical output signals	All levels configurable - simultaneous sink and source output 0 mA: fault 2 mA: dirty optics 4-20 mA: 0-100% LEL 24 mA: over range
Status light	Green - normal function Orange - fault Red - detecting gas 22 other conditions indicated by flash rate
Communications	Modbus RS485 serial link
Functional testing	Flow adaptor for gassing
Accuracy	±2% of gas reading @ ≤ 50% LEL ±5% of gas reading @ > 50% to 100% LEL
Response time	<7 seconds - T ₉₀ <3 seconds – instantaneous high levels of gas
Temperature range	-40°C to 65°C (-40°F to 149°F)
Humidity range	0 to 99% RH non-condensing
European Approvals and Standards	ATEX II 2G EEx d IIB+Hydrogen T6 Safety Cert. No: DEMKO01ATEX130838 Suitable for use in Zone 1 or Zone 2 Hazardous Areas
UL Approval and Standards	T _{amb} = -40°C to 65°C EN50014, EN50018 Class 1, Div 1, Groups B, C & D T _{amb} = -20°C to 65°C UL 1203 (When connected to a class 2 Power Supply)
Ingress protection	IP66 (jets of water) IP67 (temporary submersion), NEMA 4X
Light immunity	Totally immune to all external light, both constant and modulated (including sunlight, white light, flashing beacons etc.)
General immunity	Totally immune to all catalyst poisons
Electromagnetic compatibility	Gas detection standard EN50270 RF emissions EN50081-2 RF immunity EN50082-2

www.ert.pt

info@ert.pt

Tel: 217 142 066 - Fax: 217 145 674

Rua Soeiro Pereira Gomes, Lote 5, Cave Drl.
2845-387 Amora Portugal

A HALMA COMPANY

P03005 Issue 6 08/05

UK Office
Crowcon Detection Instruments Ltd
2 Blacklands Way
Abingdon Business Park
Abingdon
Oxfordshire OX14 1DY
United Kingdom
Tel: +44 (0) 1235 557700
Fax: +44 (0) 1235 557749
Email: crowcon@crowcon.com
Web Site: www.crowcon.com

USA Office
Crowcon Detection Instruments Ltd
21 Kenton Lands Road
Earlanger
Kentucky 41018-1845
USA
Tel: +1 859 957 1039 or
1-800-5-CROWCON
Fax: +1 859 957 1044
Email: sales@crowconusa.com
Web Site: www.crowcon.com

Rotterdam Office
Crowcon Detection Instruments Ltd
Vlambloem 129
3068JG, Rotterdam
Netherlands
Tel: +31 10 421 1232
Fax: +31 10 421 0542
Email: crowcon@crowcon.net
Web Site: www.crowcon.net

Singapore Office
Crowcon Detection Instruments Ltd
Block 194 Pandan Loop
#06-20 Pantech Industrial Complex
Singapore 128383
Tel: +65 6745 2936
Fax: +65 6745 0467
Email: sales@crowcon.com.sg
Web Site: www.crowcon.com