

O₂ Sensor

BCP-O₂

O₂ measurement in the process



Advantages & Applications

Easy, efficient und precise optimization of processes

BCP-O₂ is a reliable and uncomplate sensor for the measuring of the oxygen rate in real time. Processes in bio-processing are optimized efficiently and precisely.

The field of application is large - whether in the shake flask or in the fermenter, in the laboratory or on the industrial scale. BCP-O₂ is favourably priced, longterm stable and is already often used in parallel bioreactors. For the parallel control of O₂ and CO₂ in growth analysis for scale-up applications, we additionally offer BCpreFerm as a ready-to-use analysis system.

BCP-O₂ has already proven its worth excellently. Also maintenance is more than easy and the costs of operation very low. The sensor convinces by its robust, compact housing, an exact calibration and is measuring on the spot, directly where the process takes place.

Thanks to its universal connections, the sensor can be easily integrated in existing off-gas lines. Wherever your process takes place - in glass flasks, the fermenter or of course also for the use of disposables - the BCP-O₂ series is always the right choice.



BCpreFerm



Sampling, gas cooling or additional complicated gas lines are not longer needed. Thanks to the standard interfaces the data can be readout in real time by any electronic process control system or PC.

Connections

for every application

BCP-O₂ by BlueSens disposes of universal installation options. By its multifunctional connections each sensor can be integrated in almost every existent system. BCP-O₂ is a reliable sensor for the laboratory and the industrial use. You have the choice between a robust version with aluminum housing (IP 65) or a compact version with a PA-plastics housing. So the sensor can be installed quickly and cost-effective. In general you have the option to use flow adapters or existing screwed connections. The installation can take place by the following different connections:

- > hose connection for hoses from 4 to 12 mm
- > GL45 screw thread
- > 1 ¼" screw thread
- > Tri-Clamp

For the use of flow adapters you can make your choice between the reasonably priced and robust POM-adapters or the high-quality stainless steel adapters. Then the gas flow to/in flow adapters is simply achieved via hose connections.

flow adapter POM for hose connections



PA-housing with flow adapter stainless steel



PA-housing with GL45 screwed connection on shake flask



Tri-Clamp SMS38



Tube with screwed connection 1 ¼"

Process control

In search of the best yield

Whether in the laboratory or on the industrial scale - bioprocessing always means the control of biological processes in real time. More information about the bioprocesses means more control options. To better understand complex bioprocesses, you depend on a high data stream. BCP-O₂ detects these data for you in real time. In consequence, this information can be processed by any kind of process control system.

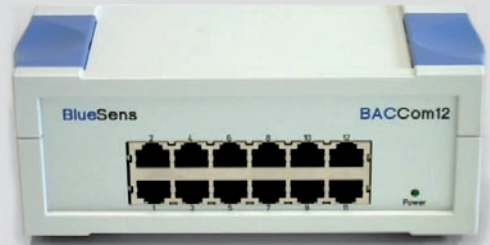

Multiplexer BACCom 12

The values can be transferred without any problem by standard data interfaces (RS 232, RS 485, 4-20 mA or Ethernet) to the bioprocessing systems. So BCP-O₂ can be integrated without any problem in existing control systems. In combination with our CO₂ sensor, the BlueSens BCP-CO₂, fermentation processes can be analyzed highly specific. Using our Multiplexer BacCom, up to 12 sensors can be bundled by a single interface. The more you learn about the bioprocess, the better you will be able to control and automate it to maximized yield.

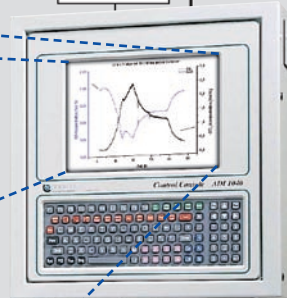
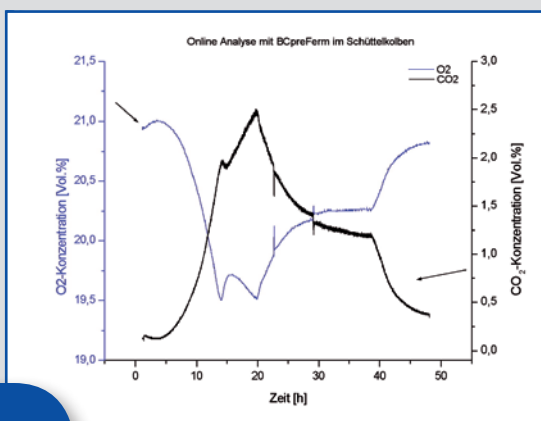
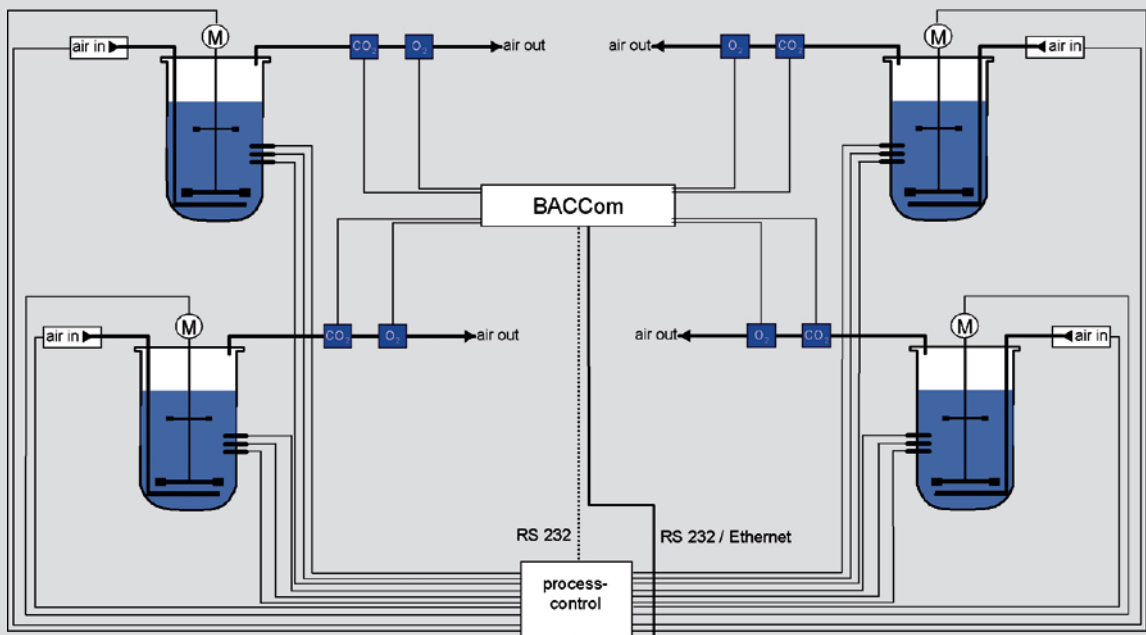

With BACVis, FERVis etc.

Parallel systems

dependable and reliable

The in-situ measurement on parallel bioreactors offers various advantages compared to the conventional method with a single central gas analyzer. The measurement of oxygen concentration by BCP-O₂ directly in every single fermenter saves the installation of complicated gas lines to a central analyzer and also the complicated processing of the gases can be left out.

According to PAT, each fermenter processes its own sensor which transfers continuous data in real time to control the process. This is a real advantage in bioprocessing. Such a continuous data stream is extremely difficult to be produced. The central analyzers are often extremely expensive to purchase and to maintain. Often the entire process is on hold, if a component has to be changed or maintained. With the use of many decentralized sensors this problem can be eliminated. When a fermenter is turned off due to maintenance, the remaining bioreactors can continue production without any problems. With the use of parallel systems you achieve much faster results in research. Under identical environments of cultivation, you can focus your testing on particular bioreactors and more quickly discover the relevant factors (DOE).

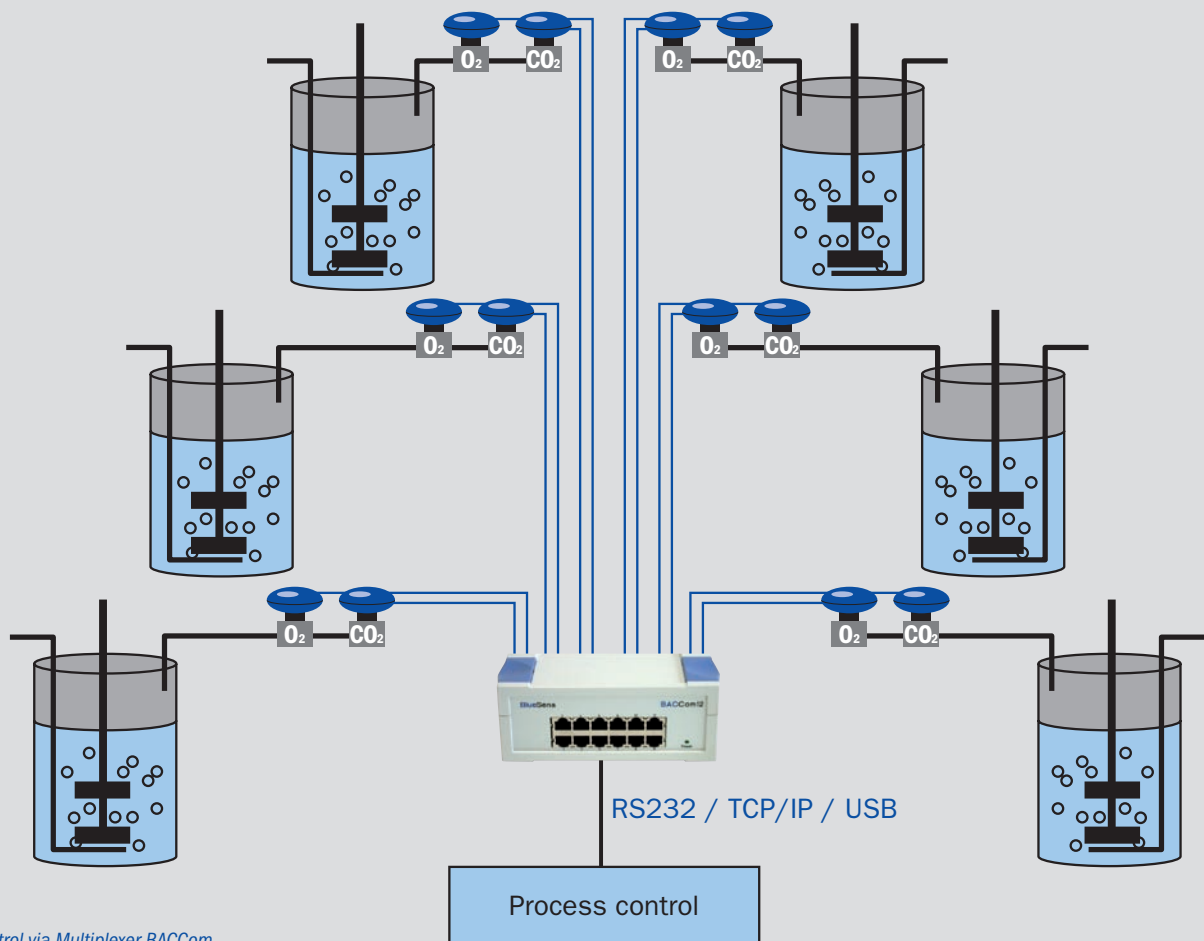

Control via Multiplexer BACCom

Software

FermVis for the parallel measurement of CO₂ and O₂

Der BCP-O₂ can be used almost anywhere. Both screwed and clamped connections and the standardized data transfer allow the integration in almost every biotechnical plant. You are also free in the software choice for the process control.

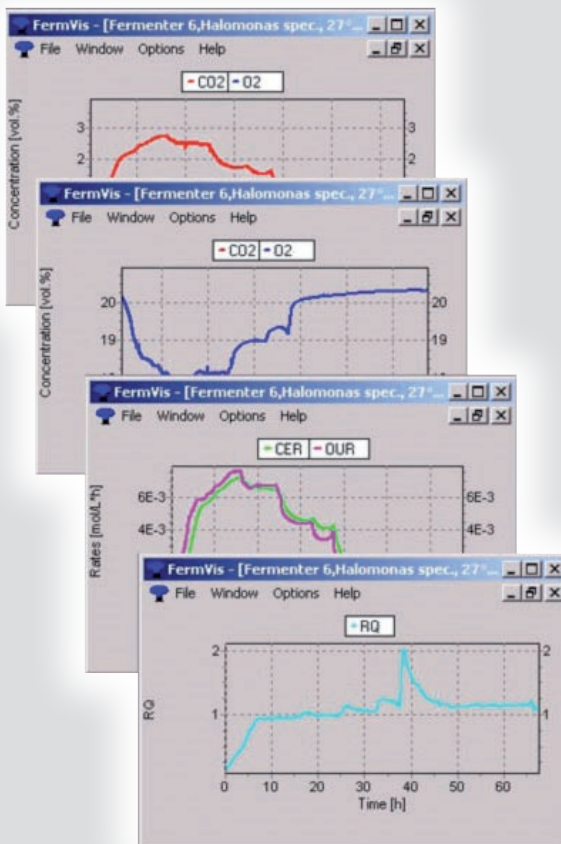

FermVis

The use of the conductible FermVis software is obvious for the parallel measurement of CO₂ and O₂. Oxygen or substrate limitations can be detected along with metabolic transpositions.

Furthermore, a time specific analysis of the respective products is made possible. For improved comparability, the BCpreFerm measurement system can be used for shake flasks and fermenters. FermVis calculates the oxygen uptake rate (OUR), the carbon dioxide emission rate (CER) and the respiratory quotient (RC).

Data sheet



Sensor	BCP-O₂		BCP-O₂ec	
Measuring principle	Zirconium dioxide		Galvanic cell	
Measuring range	0,1-25 Vol.%, 1-50 Vol.%*		0-100 Vol.%*	
Drift	< ± 2% value / year		< ± 2% value / year	
Accuracy	<0,2% FS** ± 3% value		<0,2% FS** ± 3% value	
Housing	Aluminium (IP65), PA		Aluminium (IP65), PA	
Dimension/Weight	100x100x130 mm WxDxH/750g (Aluminium) 80x130mm DxH/150g (PA)		100x100x130 mm WxDxH/750g (Aluminium) 80x130mm DxH/150g (PA)	
Mechanical connector	G 1¼", GL 45, Tri-Clamp SMS38, hose connection 4-12 mm etc.		G 1¼", GL 45, Tri-Clamp SMS38, hose connection 4-12 mm etc.	
Temperature range*	-25°C - +55 °C, 15 °C - +40 °C 30 °C - +55 °C	-13°F - +131°F 59 °F - +104°F 86 °F - +131°F	-25°C - +55 °C, 15 °C - +40 °C 30 °C - +55 °C	-13°F - +131°F 59 °F - +104°F 86 °F - +131°F
Temperature inside of the sensor unit	580°C Don't use in explosive atmosphere	1076°F	3°C higher than process temperature	5.4°F higher than process temperature
Storage temperature	0 °C - +60 °C < 75%RH non-condensing	32°F - 140°F	0 °C - +60 °C < 75%RH non-condensing	32°F - 140°F
Pressure range	0,8-1,3 bar	11.6 - 18.85 psi	0,8-1,3 bar	11.6 - 18.85 psi
Lifetime of sensor element	approx. 15.000 operating hours		approx. 900 000 Vol.% hours	
Power Supply	12 oder 24 V DC, 1A		12 oder 24 V DC, 1A	
Output	RS232, RS485, 4-20mA, Ethernet (with BACCom), USB		RS232, RS485, 4-20mA, Ethernet (with BACCom), USB	
Remarks	Don't use in explosive atmosphere, in anoxic atmosphere, in gases with polymers or silicon components or in gases with halogens (F, Cl, Br...), CFC or SO _x and H ₂ S		High concentration of NH ₃ or O ₃ could minimize the lifetime	

**others on request **FS full scale